



USEFUL TIPS

Before you begin, review the step-by-step assembly guide.

Carefully un-box the product. To prevent scratching, avoid using sharp blades when removing plastic wrapping. Lay a blanket or soft cloth on your work area to prevent damage during assembly.

Do not to over-tighten hardware. Always check for proper alignment before fully tightening hardware.

TOOLS

- » 7/16" Socket or Wrench
- » 5/32 Allen Key
- » Safety Gloves & Glasses



VIDEO HELP

Scan the QR Code to watch a video of the assembly process.

SAFETY FIRST

Always wear task appropriate protective gear such as OSHA-approved glasses, gloves, work boots, etc. Make sure you have all supplemental materials, including hardware and parts prior to beginning. Always follow instructions.

Remember: Improper use of tools or hardware may result in damage to the product or personal injury.

QUESTIONS? CONTACT US.



Orders@SeaWardSystems.com



HARDWARE DETAIL

To help prevent damage to powder coating all hardware **MUST** be installed following the order in our assembly guide.

VERY IMPORTANT: A nylon washer MUST always be placed between the powder coat and metal hardware.

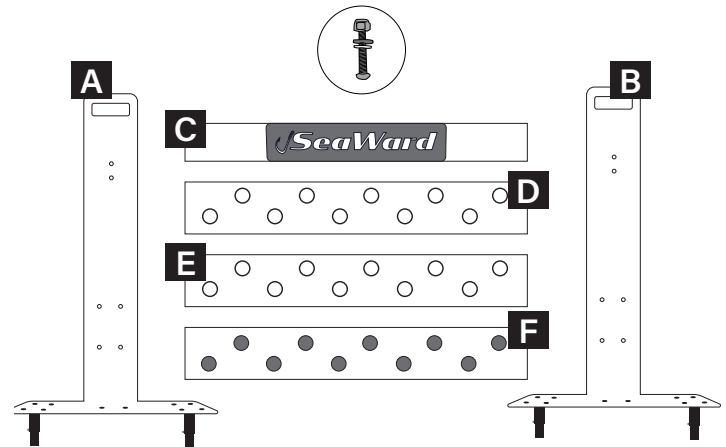
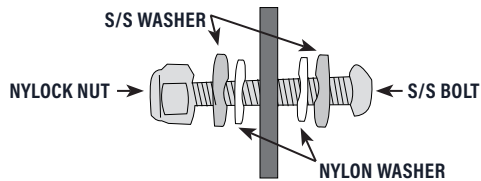

HARDWARE (included)

- » 1/4-20 @ 1" S/S Long Bolts (16)
- » White Nylon Washers (28)
- » 1/4" S/S Flat Washers (28)
- » 1/4-20 Nylock Nuts (16)

1 Step 1

HARDWARE

- » 1/4-20 @ 1" S/S Long Bolts (4)
- » White Nylon Washers (8)
- » 1/4" S/S Flat Washers (8)
- » 1/4-20 Nylock Nuts (4)

STEPS

- » Assemble part A & B to part C
- » Bolt together hand tight

* make sure holes are offset toward the rear of the caddy

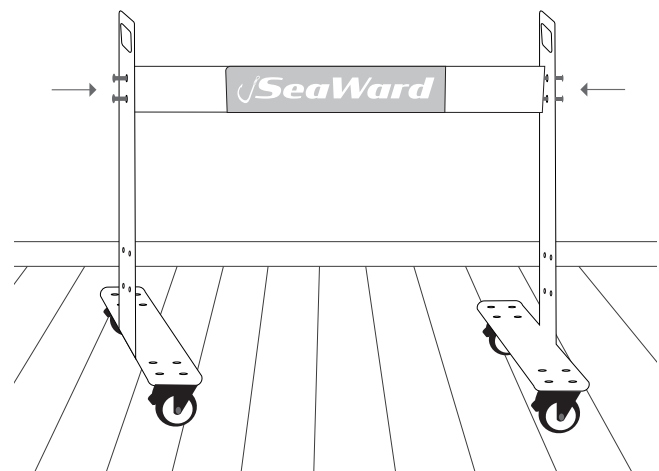

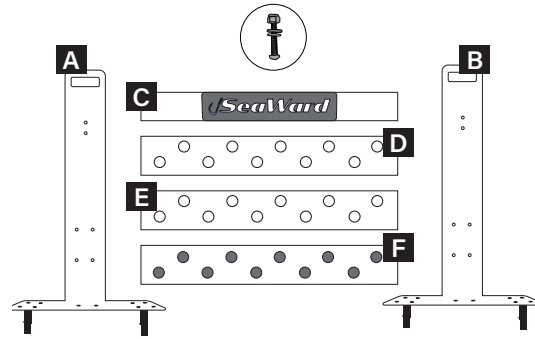

2 Step 2

HARDWARE

- » 1/4-20 @ 1" S/S Long Bolts (4)
- » White Nylon Washers (8)
- » 1/4" S/S Flat Washers (8)
- » 1/4-20 Nylock Nuts (4)

STEPS

- » Assemble part A & B to part D
- » Bolt together hand tight

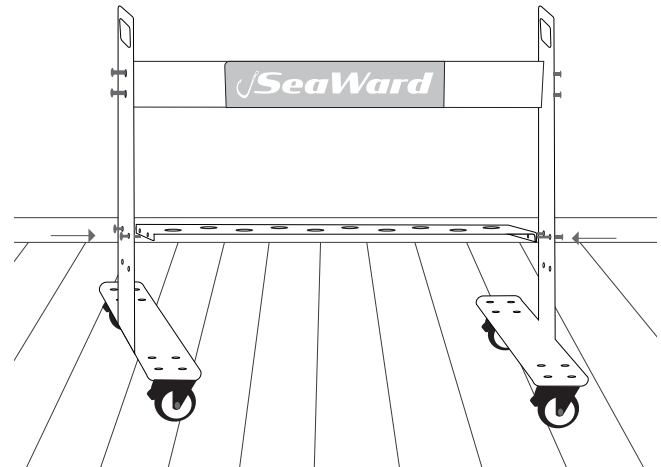

3 Step 3

HARDWARE

- » 1/4-20 @ 1" S/S Long Bolts (4)
- » White Nylon Washers (8)
- » 1/4" S/S Flat Washers (8)
- » 1/4-20 Nylock Nuts (4)

STEPS

- » Assemble part A & B to part E
- » Bolt together hand tight

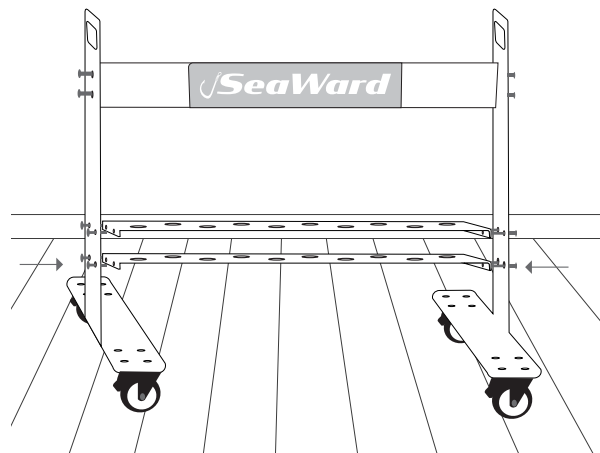

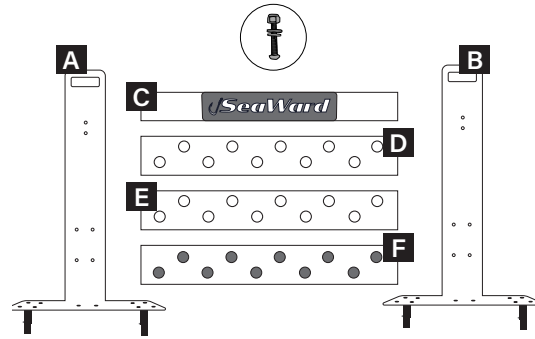

4 Step 4

HARDWARE

- » 1/4-20 @ 1" S/S Long Bolts (4)
- » White Nylon Washers (4)*
- » 1/4" S/S Flat Washers (4)*
- » 1/4-20 Nylock Nuts (4)

*Do not use nylon washers where bolts touch KingStarboard

STEPS

- » Assemble part A & B to part F
- » Bolt together hand tight

*Confirm that all the holes line up before part F is assembled

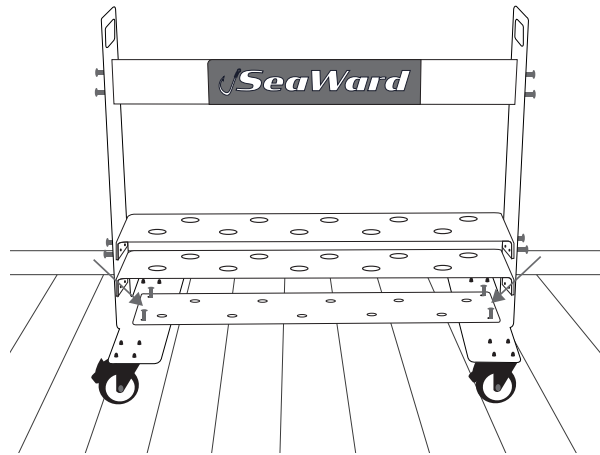

5 Step 5

STEPS

- » Tighten bolts & stand caddy upright
- » Adjust alignment & confirm bolts are secured

*It is recommended to tighten bolts with a 90° angle 5/32 allen key

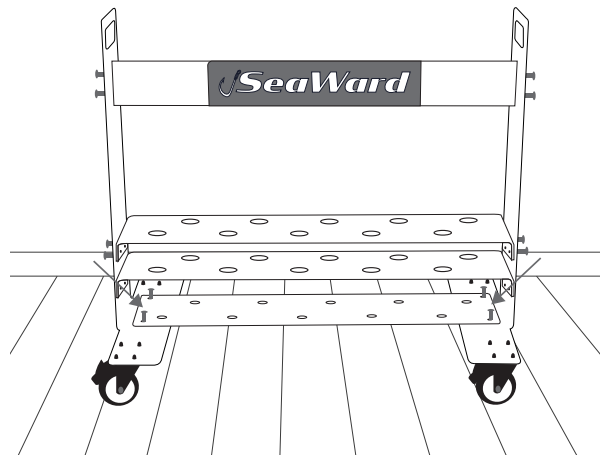

FINAL CHECK

Check that all hardware is securely fastened and the Glide caddy is stable before placing your rods in it.

