

PREASSEMBLED PARTS

- » King StarBoard Rod Rest
- » Polypropylene Caster Wheels
- » Rubber Grommets
- » Logo Plate (if applicable)

ASSEMBLY HARDWARE (included)

- » 1/4-20 @ 1" S/S Long Bolts (16)
- » White Nylon Washers (28)
- » 1/4" S/S Flat Washers (28)
- » 1/4-20 Nylock Nuts (16)

TOOLS (customer responsibility)

- » 7/16" Socket or Wrench
- » 5/32 Allen Key
(for easiest installation)



HARDWARE DETAIL

To help prevent damage to powder coating such as chipping, scratching, oxidizing, etc., all hardware **MUST** be installed following the order in our installation guide.

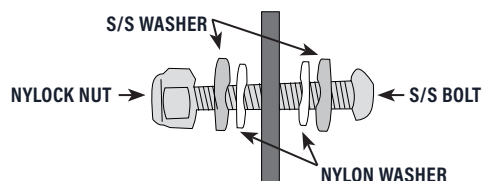

IMPORTANT

Safety is the #1 goal. Always wear task appropriate protective gear such as OSHA-approved glasses, gloves, work boots, etc. Make sure you have all supplemental materials and included hardware and parts prior to beginning the installation process.

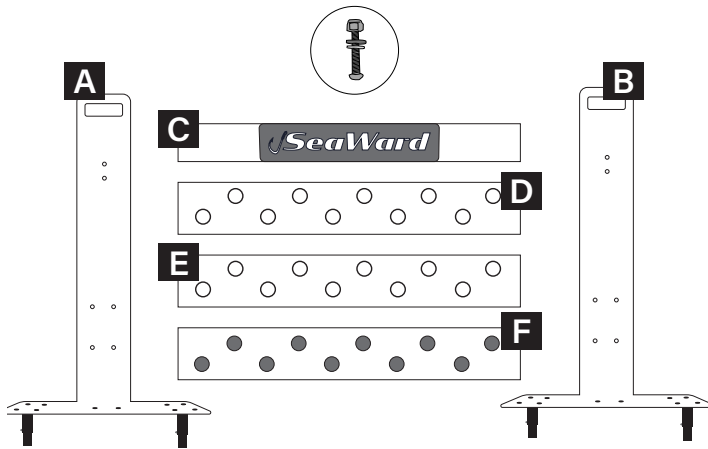

Rod Caddy Installation:

To ensure product longevity, hardware **MUST** be installed following the order in our installation guide.

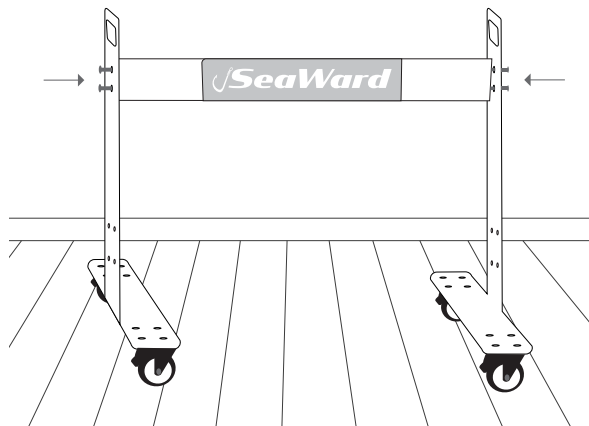
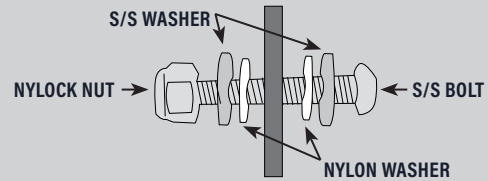

STEP 1

- » Assemble part A & B to part C
- » Bolt together hand tight

*make sure holes are offset toward the rear of the caddy

HARDWARE TO USE

- » 1/4-20 @ 1" S/S Long Bolts (4)
- » White Nylon Washers (8)
- » 1/4" S/S Flat Washers (8)
- » 1/4-20 Nylock Nuts (4)

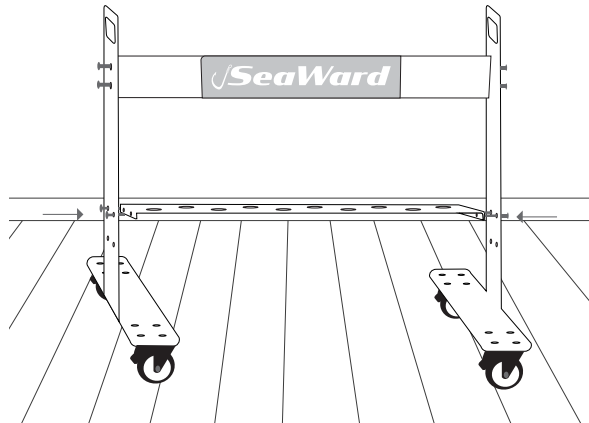

STEP 2

- » Assemble part A & B to part D
- » Bolt together hand tight

HARDWARE TO USE

- » 1/4-20 @ 1" S/S Long Bolts (4)
- » White Nylon Washers (8)
- » 1/4" S/S Flat Washers (8)
- » 1/4-20 Nylock Nuts (4)



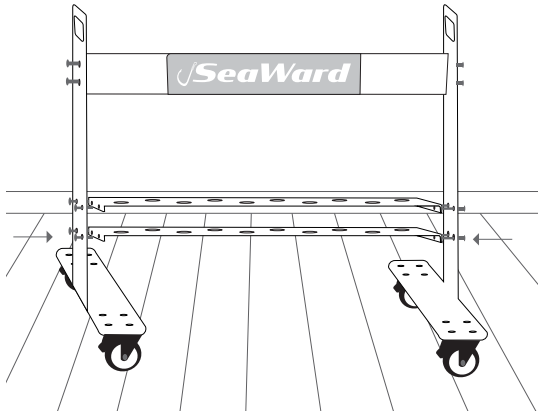

STEP 3

- » Assemble part A & B to part E
- » Bolt together hand tight

HARDWARE TO USE

- » 1/4-20 @ 1" S/S Long Bolts (4)
- » White Nylon Washers (8)
- » 1/4" S/S Flat Washers (8)
- » 1/4-20 Nylock Nuts (4)

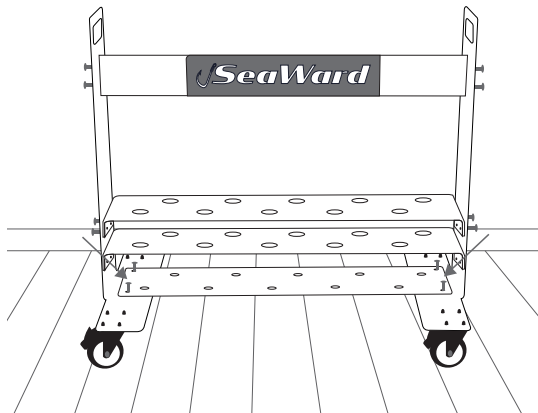

STEP 4

*Confirm that all the holes line up before part F is assembled

- » Assemble part A & B to part F
- » Bolt together hand tight

HARDWARE TO USE

- » 1/4-20 @ 1" S/S Long Bolts (4)
- » White Nylon Washers (4)*
- » 1/4" S/S Flat Washers (4)*
- » 1/4-20 Nylock Nuts (4)

*Do not use washers where bolts touch KingStarboard

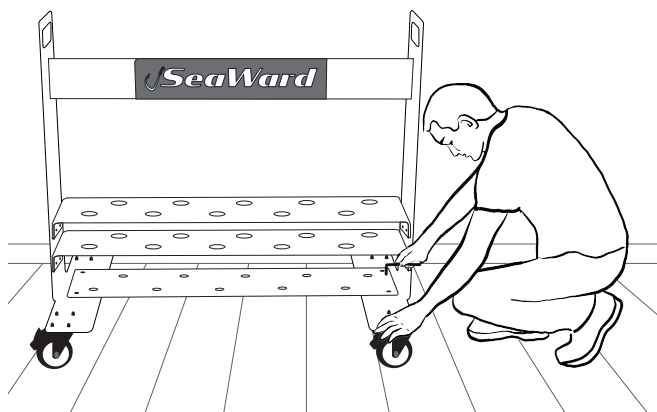

STEP 5

- » Tighten bolts & stand caddy upright
- » Adjust alignment & confirm bolts are secured

*It is recommended to tighten bolts with a 90° angle 5/32 allen key



VIRTUAL INSTRUCTIONS

Scan the QR Code to view a step-by-step virtual demonstration of the assembly instructions.

HAVE QUESTIONS?

Contact our installation team at:
Orders@SeaWardSystems.com
or **954-571-2339 x102**

