



USEFUL TIPS

Before you begin, review the step-by-step assembly guide. For safety and accuracy, it is helpful to assemble the product with 2 people.

Carefully un-box the product. To prevent scratching, avoid using sharp blades when removing plastic wrapping. Lay a blanket or soft cloth on your work area to prevent damage during assembly.

Do not to over-tighten bolts. Always check for proper alignment before fully tightening bolts. Be sure to securely fasten hardware before moving onto the next step.

TOOLS

- » Drill & Drill Bits
- » Wrench Set
- » Socket Set
- » Screwdriver Set
- » Phillips-head Bit Driver
- » Level
- » Safety Glasses

SAFETY FIRST

Always wear task appropriate protective gear such as OSHA-approved glasses, gloves, work boots, etc. Make sure you have all supplemental materials, including hardware and parts prior to beginning. Always follow instructions.

Remember: Improper use of tools or hardware may result in damage to the product or personal injury.

QUESTIONS? CONTACT US.



Orders@SeaWardSystems.com



**HARDWARE
DETAIL**

To help prevent damage to powder coating all hardware **MUST** be installed following the order in our assembly guide.

VERY IMPORTANT: A nylon washer **MUST** always be placed between the powder coat and metal hardware.

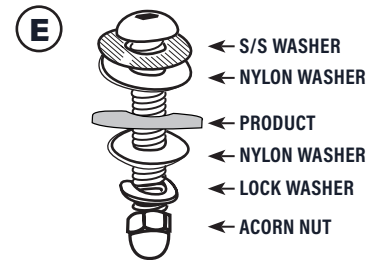
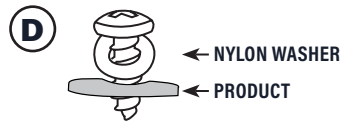
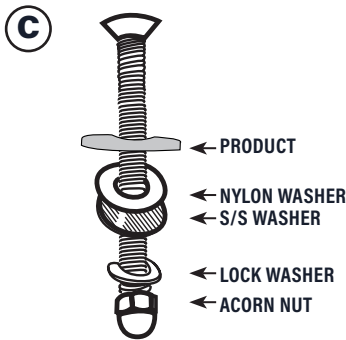
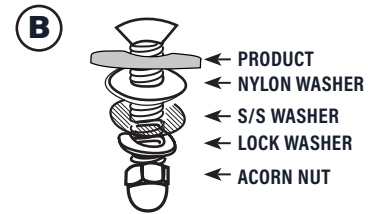
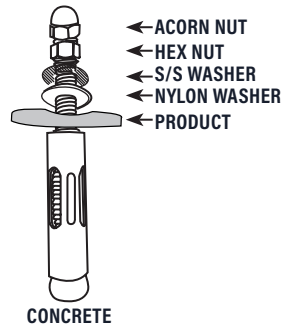
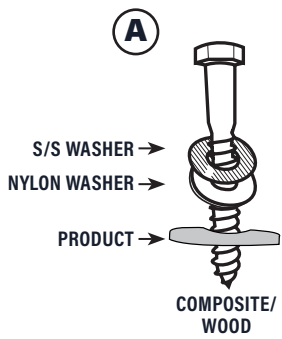

LUBRICANT USE

For all bolts, apply a small amount of Anticorrosive Lubricant to the end and the threads.



1 Mounting the Frame

HARDWARE

- » Mounting Feet Hardware Bag
- » Hardware Detail A

STEPS

- » Position one side of the frame on the mounting surface. If necessary, make sure the mounting surface is reinforced.
- » Drill pilot holes for the lag bolts or anchors.
- » Follow hardware detail A.
- » Insert bolts through the mounting foot and into the mounting surface.
- » Hand-tighten bolts to allow for adjustments.

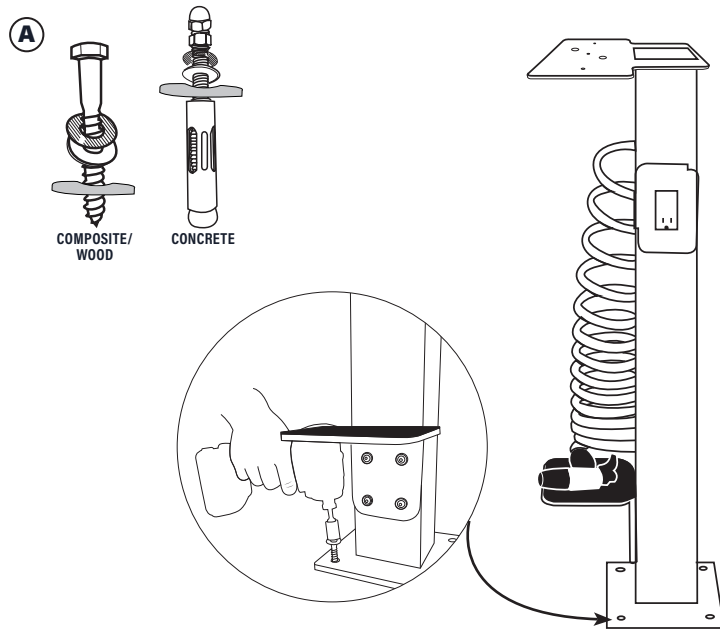

2 Attaching the Middle Support

ONLY FOR 6' & UP STATIONS

HARDWARE

- » Tabletop Hardware Bag
- » Hardware Detail B

STEPS

- » With another person, align middle support to the tabletop.
- » Follow hardware detail B.
- » Insert bolts through the tabletop, into the middle support, then hand-tighten from underneath.

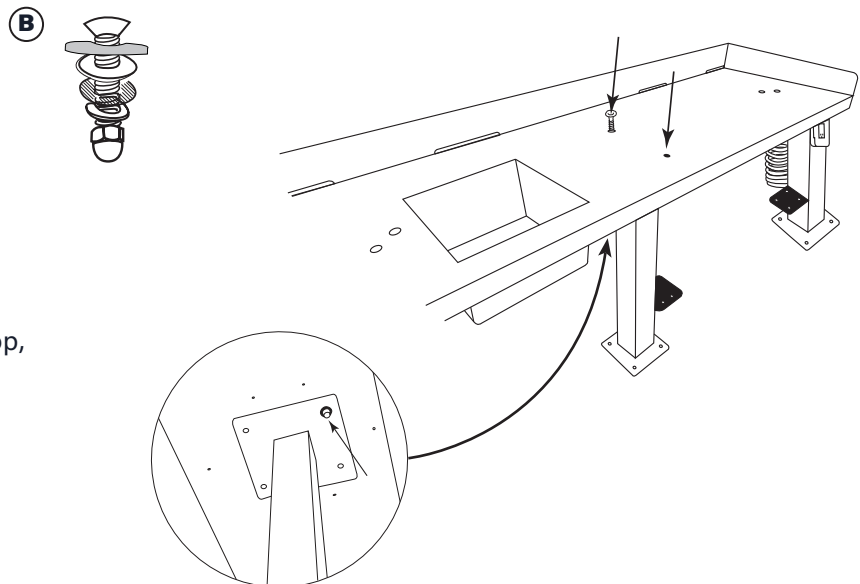

3 Attaching the Tabletop & 2nd Frame

FOR ALL STATIONS

HARDWARE

- » Tabletop Mounting Hardware Bag
- » Hardware Detail C

STEPS

- » Set the tabletop on the mounted frame, with another person holding the opposite side.
- » Follow hardware detail C.
- » Insert bolts through the tabletop to connect to the mounted frame, then hand-tighten from underneath.
- » Position the second frame.
- » Insert bolts through the tabletop to connect to the second frame, then hand-tighten from underneath.

(C)

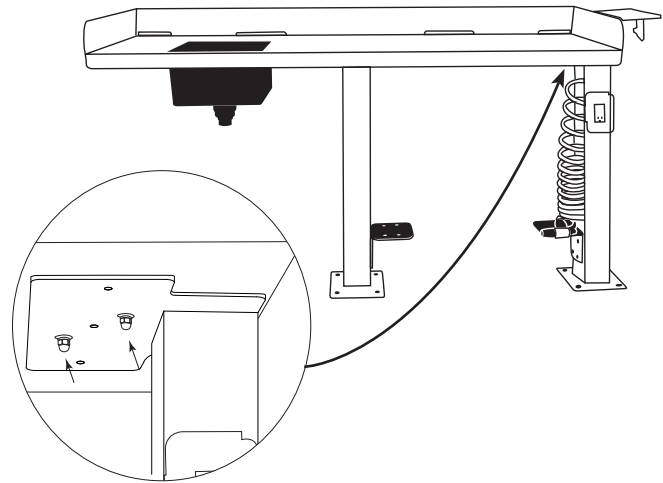

- » Follow Step 1 to secure second frame to the mounting surface.
- » Once everything is aligned, fully tighten all bolts.

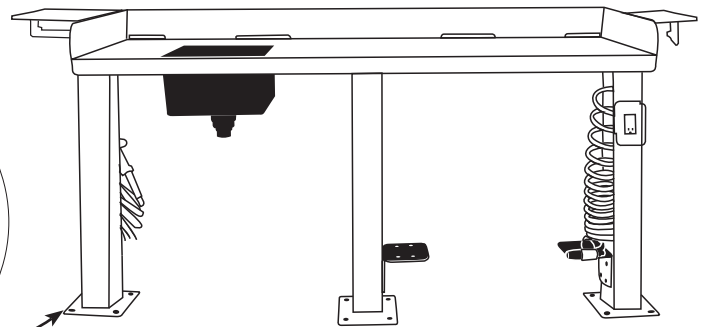
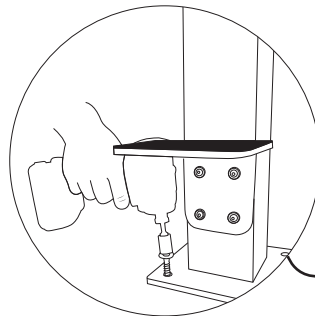

4 Attaching the StarBoard

HARDWARE

- » Tabletop StarBoard Bag
- » Hardware Detail D



STEPS

- » Position the curved edges of the StarBoard to the back of the station. Align it to the front lip of the tabletop.
- » Follow hardware detail D.
- » Holding the surface in place, insert screws from underneath.
- » Fully tighten.
- » Remove protective covering.

IMPORTANT:

Mini cabinets must be installed prior to the StarBoard. Step-by-step guide is listed in Upgrades.

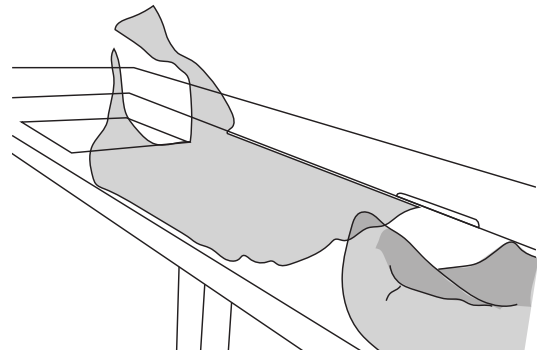

5 Adding the Upgrades

STORAGE CABINET

HARDWARE

- » Cabinet Mounting Hardware Bag
- » Hardware Detail E

STEPS

- » With another person, position the Cabinet on the L brackets, aligning the slots on the cabinet with the slots on the L bracket.
- » Follow hardware detail E.
- » Insert bolts from the inside of the cabinet through the L bracket.
- » Hand-tighten bolts to allow for adjustments.
- » Once aligned, securely tighten in a cross-hatch pattern.

SINK

FULLY ASSEMBLED

- » The sink is mounted during production.

MINI CABINET

HARDWARE

- » Mini Cabinet Mounting Hardware Bag
- » Hardware Detail C

STEPS

- » With another person, align the slots on the Mini Cabinet with the slots on the tabletop.
- » Follow hardware detail C.
- » Insert bolts from the tabletop through the inside of the cabinet.
- » Hand-tighten bolts to allow for adjustments.
- » Once aligned, securely tighten in a cross-hatch pattern.

Mini cabinets must be installed prior to the StarBoard.

